

Caesarstone Outdoor Collection

Performance Guide in Relation to
UV Resistance



Caesarstone Outdoor Collection

Performance Guide in Relation to UV Resistance

The guide is intended to explain the performance level of Caesarstone Outdoor in relation to UV resistance.

Caesarstone Outdoor is designed to have excellent performance. After thorough testing both in the lab and in the field, results have proven that Caesarstone's Outdoor surfaces are highly resistant to all seasonal weather and environmental conditions and everyday wear and tear, as well as having exceptional functional and physical properties.

In terms of UV resistance, it should be noted that no product, even when specifically designed for outdoor exposure, will retain its fullcolour over a long period of exposure in Australian outdoor conditions and it should be expected that a certain level of fading will occur. For Caesarstone Outdoor, it is estimated that a colour change of up to only 4 delta units may occur in a period of 5 years of external use.

What is a Delta Unit?

A Delta E unit is a metric for understanding how the human eye perceives colour difference. It is a single number that represents the 'distance' between two colours.

A colour change of less than or equal to $5\Delta E^*_{ab}$ units in 10 years is considered a very good choice for exterior applications. For the Caesarstone Outdoor range, the product could fade up to a level of Delta 4 over a 5 year period of external use, which is barely distinguishable and sits at the higher end of colour retention.

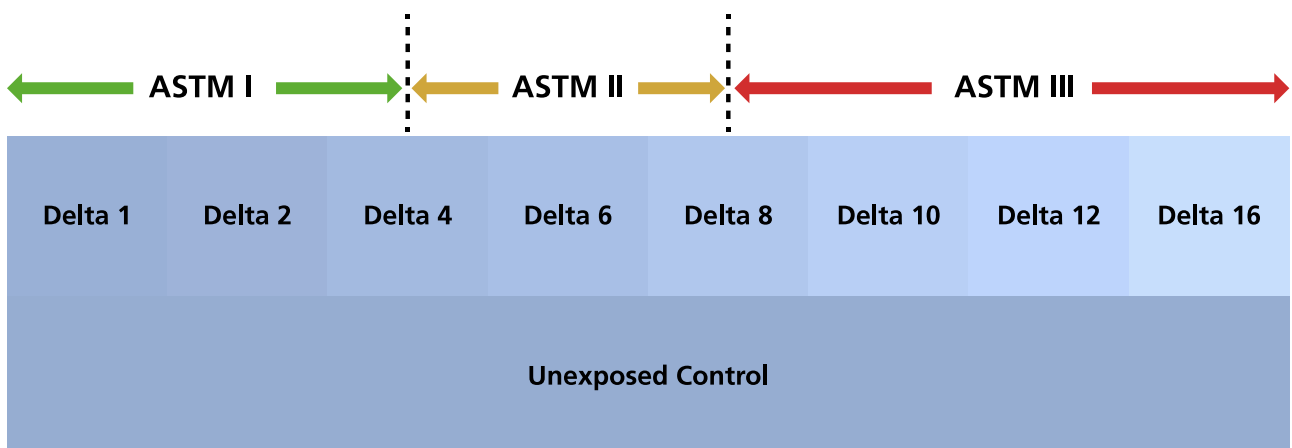
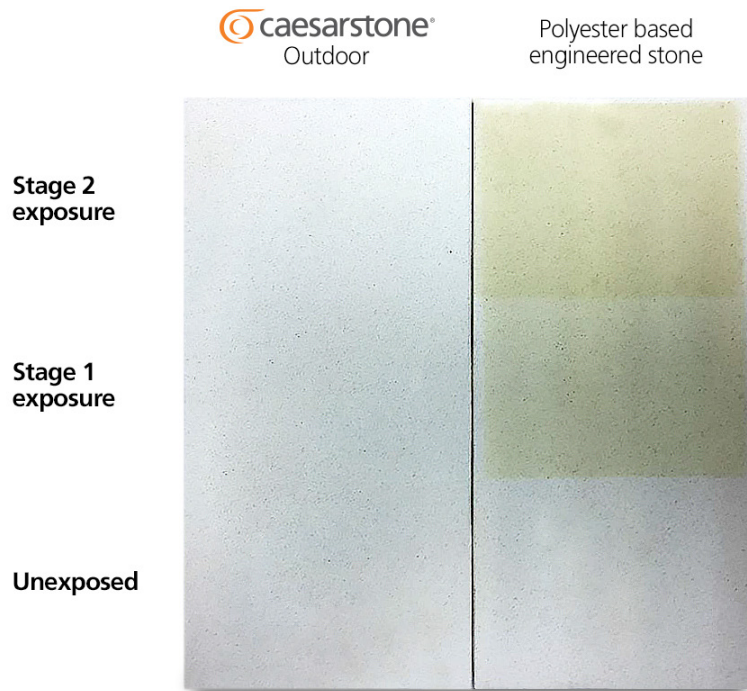

Image 2: Range of Delta E differences from an unexposed control with corresponding ASTM Lightfastness categories.

TEST RESULTS

In the image below, a Caesarstone outdoor product was tested in comparison to a standard, polyester based, engineered stone product using an accelerated UV testing protocol replicating 2+ years of exposure. The Caesarstone Outdoor product retained its original colour exceptionally well.



Furthermore, the three products in the Outdoor Collection have retained their colour after a long UV exposure duration.

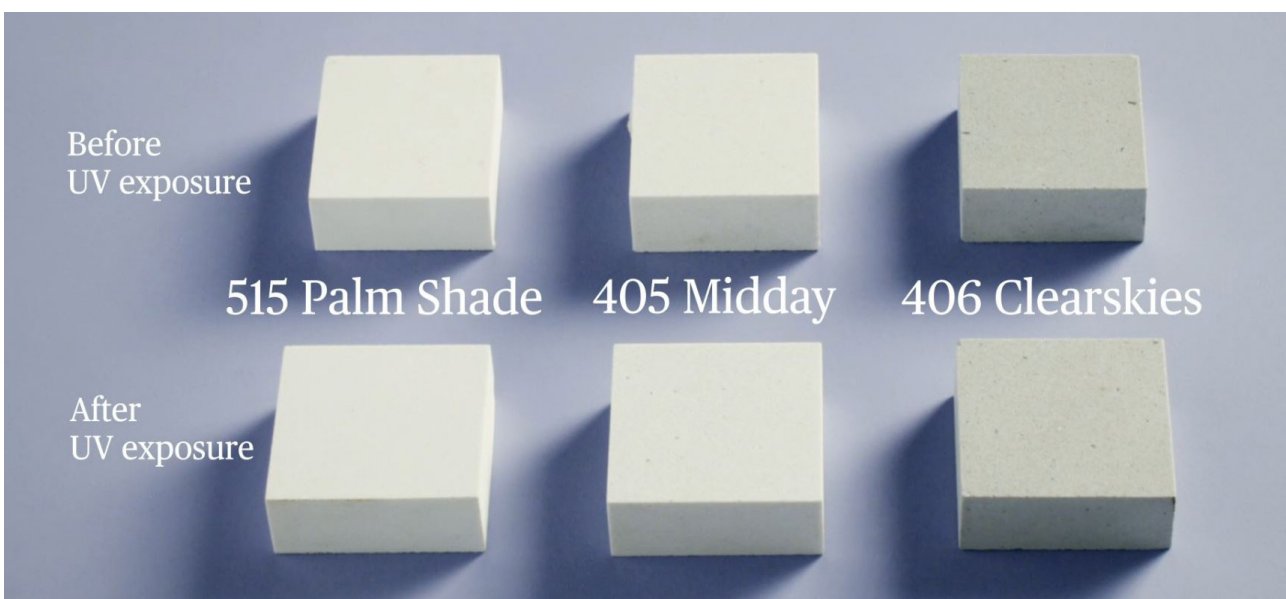

Technical Data

PROPERTY	RESULTS
Flexural Strength	>55 MPa
Freeze-thaw Resistance	No obvious damage after 20 freeze-thaw cycles
Bulk Density	>2.2 gr/cm
Water Absorption	<0.1% (per 10 days absorption)
Impact Resistance	>9 J
Stain Resistance ¹	Pass
Chemical Resistance ¹	Class C4
Thermal Conductivity	0.76 W/(m·K)
Thermal Shock	No obvious change Change in mass: -0.01%-0.04% Change in flexural strength: -2.7%-7%
Boiling Water Resistance ²	No effect
High Temperature Resistance ²	No effect
UV Resistance	Color change of up to 4 delta E units may occur in a period of 5 years of external use ³
Surface Burning	ASTM E84 (Class A)
Thermal Expansion Coefficient	$30-50 \cdot 10^{-6} \text{ }^{\circ}\text{C}^{-1}$
Ignitability (ASNZS 1530.30)	4 (Range 0-20)
Spread of Flame Index (ASNZS 1530.30)	0 (Range 0-10)
Heat Evolved Index (ASNZS 1530.30)	1 (Range 0-10)
Smoke Developed Index (ASNZS 1530.30)	3 (Range 0-10)

References above are as per the following standards:

¹ based on ANSI Z 124.6

² based on ANSI NEMA LD3-3.5

³ estimated value