

Lakepine® E0

Technical Manual

MDF
Medium Density Fibreboard

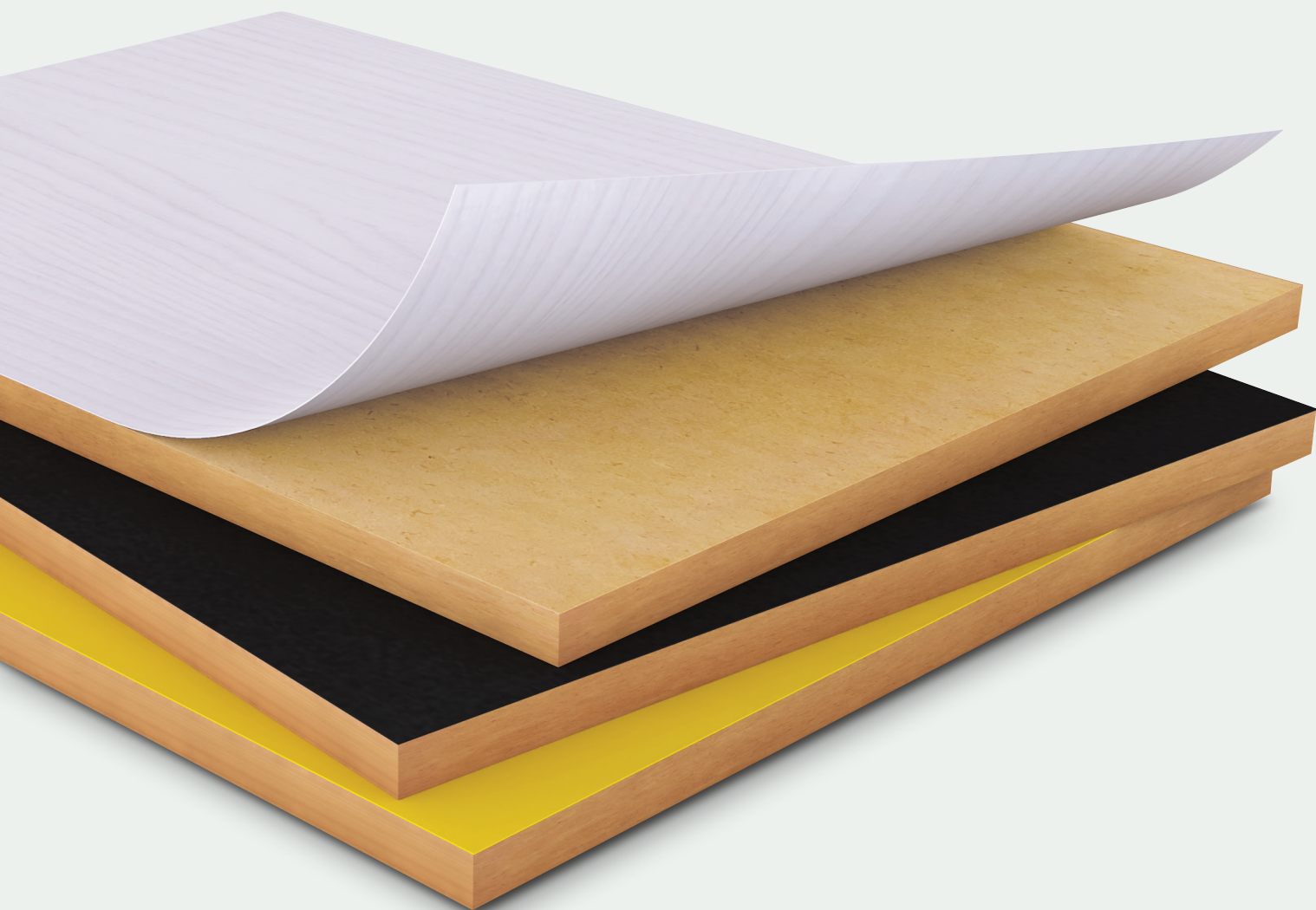

Lakepine®
E0



Lakepine®
LIGHT



Lakepine®
EO MR

Edition 2.0 12.19

Laminex™
NEW ZEALAND

Contents | Lakepine® E0

	Page	
Section 1	General Product Description	02
1.1	Lakepine® E0 material	02
1.2	Lakepine® E0 types	02
1.2.1	Lakepine® E0 MDF	02
1.2.2	Lakepine® E0 Light	02
1.2.3	Lakepine® E0 Ultralight	02
1.2.4	Lakepine® E0 MR	03
1.3	Make sure your information is up to date	03
1.4	Sustainability	03
Section 2	Material Properties	04
2.1	Lakepine® E0 MDF	04
2.1.1	Lakepine® E0 MDF typical physical properties	04
2.1.2	Lakepine® E0 MDF general board weight	04
2.1.3	Sheet tolerances	04
2.2	Lakepine® E0 Light	05
2.2.1	Lakepine® E0 Light typical physical properties	05
2.2.2	Lakepine® E0 Light general board weight	05
2.2.3	Sheet tolerances	05
2.3	Lakepine® E0 Ultralight	05
2.3.1	Lakepine® E0 Ultralight typical physical properties	05
2.3.2	Lakepine® E0 Ultralight general board weight	05
2.3.3	Sheet tolerances	06
2.4	Lakepine® E0 MR	06
2.4.1	Lakepine® E0 MR typical physical properties	06
2.4.2	Lakepine® E0 MR general board weight	06
2.4.3	Sheet tolerances	06
2.5	Composition	06
2.5.1	Manufacture	06
2.5.2	Identification	06
Section 3	Durability	07
3.1	Handling and storage	07
3.2	Heat	07
3.3	Fungal and insect resistance	07
3.4	Limitations	07
Section 4	Design	08
4.1	Design consideration	08
4.2	Framework setout	08
4.2.1	Framework support centres	08
Section 5	Installation	09
5.1	Sawing	09
5.1.1	Recommendations for tungsten carbide tipped saws and dado heads	09
5.1.2	Feed speeds for sawing MDF	09
5.1.3	Bandsaws	09
5.2	Drilling	09
5.3	Routing and edge moulding	09
5.3.1	Recommended feed speeds for routing and moulding	10
5.4	Profile sanding	10
5.4.1	Sanding	10
5.4.2	Dust extraction	10
5.5	Hand tools	10
Section 6	Fixing and Jointing	11
6.1	Balanced laminations	11
6.2	Screwing	11
6.2.1	Type of screw	11
6.3	Screw gauge	11
6.4	Pilot holes	11
6.5	Nailing	12
6.5.1	Airgun nails	12
6.6	Stapling	12
6.6.1	Recommended staples	12
6.7	Doweling	13
6.8	Adhesives	13
6.9	Block laminating	13
Section 7	Finishing	14
7.1	Finishing limitations	14
7.2	Preparation	14
7.2.1	Edge preparation	14
7.2.2	Surface preparation	14
7.2.3	Stopping	14
7.3	Brush paint application	15
7.3.1	Priming	15
7.3.2	Finishing	15
7.4	Spray coating application	15
7.4.1	Sealing	15
7.4.2	Finishing	15
Section 8	Health and Safety	16
8.1	Health and safety precautions	16
8.2	Wood dust	16
8.2	Formaldehyde	16
8.3	Warranty	16
Section 9	Disclaimer	17
9.1	Technical support	17

1 General Product Description

1.1 Lakepine® E0 material

Lakepine® E0 products have a homogeneous nature, which results in relative consistency from surface to core and high density edges. These characteristics allow intricate and precise machining and finishing techniques when producing high quality furniture and cabinetry components.

The flat smooth surface of this product is uniform, dense and free of knots and grain patterns, making finishing operations simpler and more economical. Lakepine® E0 is available in the following specifications:

1.2 Lakepine® E0 types

1.2.1 Lakepine® E0 MDF

Lakepine® E0 MDF is a low formaldehyde emitting MDF panel that meets the requirements of AS/NZS 1859 Part 2 for E0 which is classified as less than or equal to 0.5mg/L. All other properties of Lakepine® E0 MDF are similar to Lakepine® MDF, (refer to Table 1 on page 4). This applies to all Lakepine® E0 types.

Lakepine® E0 Medium Density Fibreboard (MDF) is available in 3mm to 30mm. The average densities are less than 6mm, 790kg/m³, and from 9mm 700kg/m³ to 30mm 750 kg/m³. The products all comply with AS/NZS 1859 Part 2 and are low formaldehyde emitting (E0).

Uses:

- o Kitchen units
- o Office equipment
- o Wood veneer, vinyl and paper overlays
- o Cupboard doors
- o Wall and ceiling lining
- o Pool tables
- o Shelving
- o Door skins
- o Pianos
- o Furniture
- o Stairs
- o Benchtop substrate
- o Cupboard backs
- o Shop fittings
- o Moulding trim

1.2.2 Lakepine® E0 Light

Lakepine® E0 Light is lighter in weight than Lakepine MDF E0, but maintains excellent strength quality, surface smoothness and stability. Because of its lower density, it cuts accurately and easily, leaving a clean, true edge and it is much less demanding on machinery. The surface can be painted to achieve a high quality finish and provides a uniform substrate for overlaying. Density of board for 12mm - 25mm thick is 600kg/m³.

Uses:

- o Kitchen units
- o Office equipment
- o Wood veneer, vinyl and paper overlays
- o Cupboard doors
- o Wall and ceiling lining
- o Pool tables
- o Shelving
- o Door skins
- o Pianos
- o Furniture
- o Stairs
- o Benchtop substrate
- o Cupboard backs
- o Shop fittings
- o Moulding trim

1.2.3 Lakepine® E0 Ultralight

Lakepine® E0 Ultralight has been produced with an average density that is approximately 30% lighter than Lakepine® MDF (520 kg/m³). Lakepine® E0 Ultralight is suitable for interior applications where weight of the assemble is an important consideration.

Uses:

- o Interior furniture
- o Pin-boards/noticeboards
- o Office/desk partitions
- o Laminated benchtop substrate
- o Internal door core

1.2.4 Lakepine® E0 MR

Lakepine® E0 MR is a moisture resistant Medium Density Fibreboard specifically developed to provide extra durability for furniture and joinery applications in interior areas subject to high humidity.

Uses:

- o Bathroom vanity units
- o Sealed partitions
- o High humidity regions
- o Laundry cupboards
- o Wall linings in washrooms, toilets and changing rooms
- o Sealed or laminated benchtops

1.3 Make sure your information is up to date

When specifying or installing Laminex New Zealand® product, ensure you have the current technical manual. If you are not sure you do, or you need more information, visit laminex.co.nz or call Laminex New Zealand® on 0800 303 606.

1.4 Sustainability

Lakepine E0 Medium Density Fibreboard is made in New Zealand following the best environmental practices (ISO 14001). It is sourced from FSC Certified forests, giving assurances that not only is renewable, but that it comes from forests that are managed responsibly.

Lakepine® E0 has Environmental Choice New Zealand certification, one of the highest, most trusted and recognised environmental certifications in New Zealand. This certification provides maximum points towards Homestar and Green Star within Green Building Council ratings. Green Star is a rating system for the design, construction and operation of buildings, interiors and communities, and Homestar measure the health, warmth and efficiency of New Zealand homes.



2 Material Properties

2.1 Lakepine® E0 MDF material

Medium Density Fibreboard (MDF) is an engineered wood product made by breaking down hardwood or softwood residuals into wood fibres, often in a defibrator, combining it with wax and a resin binder, and forming panels by applying high temperature and pressure.

2.1.1 Lakepine® E0 MDF typical physical properties* determined by testing to AS/NZS 4266

Property	Unit	<10mm	10 - 19mm	20 - 29mm	30 -32mm
Moisture Content	%	7	7	7	7
Density	kg/m ³	750	740-750	720	700-720
Internal Bond	MPa	0.9	0.85	0.8	0.75
Modulus of Rupture (MOR)	MPa	32	38	33	32
Modulus of Elasticity (MOE)	MPa	3200	3430	3240	3340
Surface Soundness	MPa	N/A	1.3	1.5	1.4
Face Screw Holding	N	N/A	670	710	700
Edge Screw Holding	N	N/A	910	940	900
Thickness Swell 24 hr	%	13	6	5	6
Formaldehyde Emission	mg/L	<0.5	<0.5	<0.5	<0.5

Table 1

2.1.2 Lakepine® E0 MDF general board weight

Thickness (mm)	3	4	4.75	6	9	12	16	18	25	30
Kg/m ²	2.34	3.12	3.71	4.70	6.75	9.0	11.84	13.32	18.00	21.60

Table 2

2.1.3 Sheet tolerances

(Sheet tolerances meet or exceed AS/NZS 1859 Part 2).

- o Length and width: +/- 2.0mm
- o Thickness: +/- 0.2mm
- o Squareness (maximum difference between diagonals): ≤ 2mm per metre
- o Straightness (maximum deviation from line): 1.5mm per metre
- o Sanding grit: 180

*Laminex® New Zealand reserves the right to change the specification.

2.2 Lakepine® E0 Light

2.2.1 Lakepine® E0 Light typical physical properties*

Property	Unit	10 - 19mm	20 - 29mm
Moisture Content	%	7	7
Density	kg/m ³	600	600
Internal Bond	MPa	0.6	0.6
Modulus of Rupture (MOR)	MPa	28	20
Modulus of Elasticity (MOE)	MPa	2600	2100
Surface Water Absorption	g/m ²	110	110
Thickness Swell 24 hr	%	7	5
Formaldehyde Emission	mg/L	<0.5	<0.5

Table 3

2.2.2 Lakepine® E0 Light general board weight

Thickness (mm)	18
Kg/m ²	10.8

Table 4

2.2.3 Sheet tolerances

(Sheet tolerances meet or exceed AS/NZS 1859 Part 2).

- o Length and width: +/- 2.0mm
- o Thickness: +/- 0.2mm
- o Squareness (maximum difference between diagonals): ≤ 2mm per metre
- o Straightness (maximum deviation from line): 1.5mm per metre
- o Sanding grit: 180

2.3 Lakepine® E0 Ultralight

2.3.1 Lakepine® E0 Ultralight typical physical properties*

Property	Unit	18 - 25mm
Moisture Content	%	6
Density	kg/m ³	540
Internal Bond	MPa	0.5
Modulus of Rupture (MOR)	MPa	26
Modulus of Elasticity (MOE)	MPa	2200
Thickness Swell	%	9
Formaldehyde Emission	mg/L	<0.5

Table 5

2.3.2 Lakepine® E0 Ultralight general board weight

Approximate Density (kg/m ³)	400
Thicknesses (mm)	23.5
Kg/m ²	9.4

Table 6

*Laminex® New Zealand reserves the right to change the specification.

2.3.3 Sheet tolerances

(Sheet tolerances meet or exceed AS/NZS 1859 Part 2).

- o Length and width: +/- 2 mm
- o Thickness: +/- 0.15 mm
- o Straightness (maximum difference between diagonals): 1.125 mm per metre
- o Squareness (maximum difference between diagonals): <1.5 mm per metre
- o Sanding grit: 180

2.4 Lakepine® E0 MR

2.4.1 Lakepine® E0 MR typical physical properties*

Property	Unit	10 - 19mm	20 - 29mm
Moisture Content	%	7	7
Density	kg/m ³	730	730
Internal Bond	MPa	1.1	0.95
Modulus Of Rupture (MOR)	MPa	50	50
Modulus Of Elasticity (MOE)	MPa	3700	3500
Surface Soundness	MPa	0.9	0.9
Face Screw Holding	N	1600	1500
Edge Screw Holding	N	670	700
Thickness Swell 24 Hr	%	7	6
Formaldehyde Emission	mg/L	≤0.5	≤0.5
Internal Bond After Wet Cyclic Test	MPa	0.2	0.15
Thickness Swell After Wet Cyclic Test	%	9	6
Wet Bending Strength	MPa	5	4

Table 7

2.4.2 Lakepine® E0 MR general board weight

Thicknesses (mm)	12	16	18	25
Kg/m ²	26.8	35.7	40.2	55.8

Table 8

2.4.3 Sheet tolerances

As per Lakepine® E0 MDF.

2.5 Composition

2.5.1 Manufacture

The raw material used in Lakepine® E0 products is selected from a range of renewable plantation pine species. The panels are manufactured from dried wood fibres which are bonded together under heat and high pressure using urea-formaldehyde resin.

The pressed panels are fine-sanded to a smooth and consistent appearance and then sawn to size. All stages of manufacture are subject to rigid quality control with regular tests being made as the panels leave the production line.

2.5.2 Identification

Sheets are light brown in colour and are marked on the edge with blue indicator. Packs are clearly branded with a distinctive Lakepine® E0 label describing pack contents.

*Laminex® New Zealand reserves the right to change the specification.

3 Durability

When stored, handled and used in accordance with this document, Lakepine® E0 products will meet the durability requirements of NZBC B2.3(d) for furniture and joinery applications for five years.

Various assembly fittings, hardware items, coatings and glues are referred to within this document for use in conjunction with Lakepine® E0 products. These items must be used in accordance with the manufacturer's instructions. Laminex New Zealand® accepts no liability for the use of these proprietary products.

Lakepine® E0 products must be laminated, painted, stained or clear finished to prevent moisture getting into the panel. Lakepine® E0 has superior machining and finishing characteristics, strength and stability making it ideal as the prime component in many applications.

Laminex New Zealand® will not be liable to any person if the conditions as to storage, handling and use of Lakepine® products as outlined within this document are not complied with.

3.1 Handling and storage

Store away from moisture, heat and direct sunlight. Correct storage will eliminate sagging and distortion of sheets (refer Figure 1).

When stacking packs of Lakepine® E0 products, line gluts vertically one above the other.

At the time of dispatch Lakepine® E0 has a low moisture content. Because of this a minimum conditioning interval of 48 hours is required prior to use.

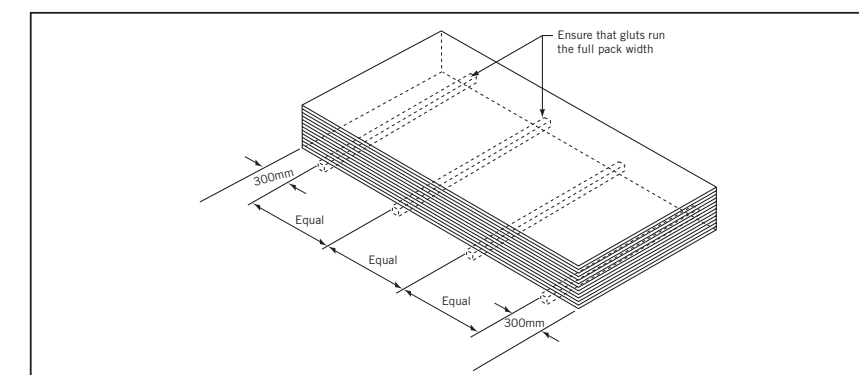

Figure 1

3.2 Heat

Precautions must be taken to ensure that Lakepine® E0 product is kept clear from nearby sources of heat, such as free-standing fire places, space heaters, wall ovens, hot plates etc. The structural life of Lakepine® E0 may be impaired if surface temperatures exceed 50°C.

Manufacturers of heat appliances (such as previously mentioned) must be consulted to ascertain the clearances or protection required to ensure 50°C is not exceeded.

3.3 Fungal and insect resistance

Lakepine® E0 will resist fungal and insect attack provided the board moisture content does not exceed 20% for extended periods of time.

3.4 Limitations

It is not intended that Lakepine® E0 products get wet. As such the product must not be used in an external location. When used where accidental water spill can occur, all surfaces must be suitably sealed. Special care must be taken at the intersection of panels and accessories (Hardware and edging etc.) to ensure moisture cannot penetrate the substrate.

4 Design

4.1 Design considerations

When used as a wall or ceiling lining attention must be given to site storage, pre-conditioning at point of installation and provision of specified joint clearances to ensure the effects of moisture uptake during and after installation are minimized.

Panel pre-conditioning prior to installation is of utmost importance, especially during periods of high rainfall and accompanying high humidity. (Refer figure 2).

Installation of Lakepine® E0 panels as wall or ceiling linings must not take place until the structure is closed in and waterproof.

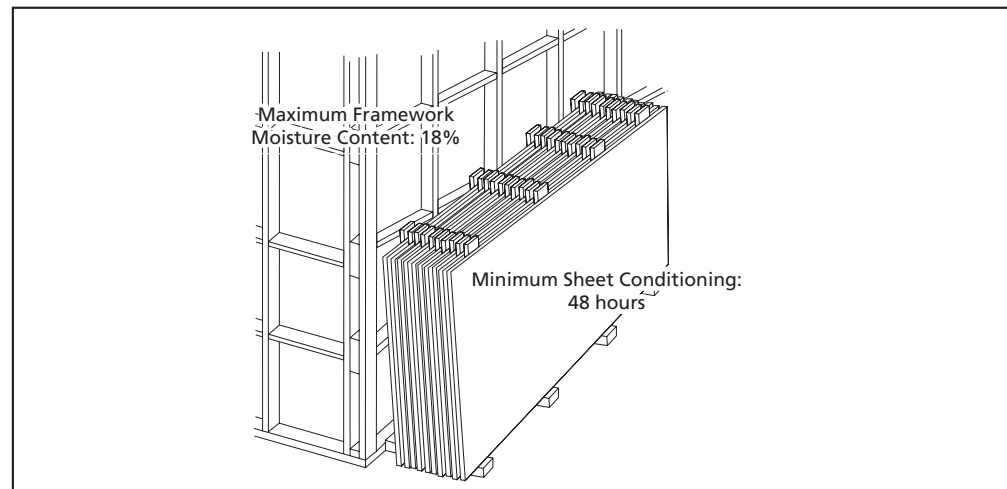

Figure 2

4.2 Framework setout

Lakepine® E0 panels must not be placed in close proximity to framework with moisture content in excess of 18%. Allow for the stud, rafter, beams etc. to accommodate a minimum 2mm expansion gap at panel edges especially where large areas or long walls are to be covered. Where panels are abutting structural elements including beams and posts, or any concrete/masonry products, a minimum clearance of 10mm is recommended.

4.2.1 Framework support centres

Wall Lining			Ceiling Lining	
Panel Thickness (mm)	Stud Centres (mm)	Dwang Centres (mm)	Joist/Truss Centres (mm)	Dwang Centres (mm)
12	400	1200	450	1200
	450	1200	600	1200
	600	800	900	600
18	400		1200	600
	450		900	1200
	600	1200	1200	900

Table 9

5 Installation

5.1 Sawing

- o Tungsten-tipped blades should be used for high quality and larger volumes.

5.1.1 Recommendations for tungsten carbide tipped saws and dado heads

Chip load/tooth: 0.15 - 0.25mm Radial clearance: 1 - 2 degrees.

Side clearance: 3 - 4 degrees. Tip to body: 0.64 - 1.00mm.

O.D. clearance: 20 - 22 degrees. Hook Angle: 10 - 15 degrees.

- o Saw blades should have higher clearance angles and increased hook angles compared with normal wood working saws.
- o Sawing equipment must be well maintained, with replacement of blades at the first sign of any visible deterioration of the cut edge.
- o Correct feed speed is important as too slow a speed reduces the bite and can abrade tool tips.
- o When cutting laminated Lakepine® E0 on a saw bench place the decorative surface uppermost. For double sided overlays, a bench-saw with a scribing saw or hollow ground main blade is essential to avoid chipout.

5.1.2 Feed speeds for sawing MDF

Cutting saw speeds 3600 rpm

Diameter per saw (mm)	250	300	350	400	450	500
Teeth per saw	60	72	84	96	108	120
Rim speed m/sec	47	56	66	75	85	94
Feed speed m/min	32	39	45	52	58	65

Table 10

- o When using a portable electric saw, place the face on the underside. For double sided overlays use a backing board on the top face or cut oversize and trim with a router or planer.

5.1.3 Bandsaws

The use of bandsaws for cutting Lakepine® E0 products is not recommended for long production runs. For short runs use a quality high speed steel blade with three teeth per 25mm.

5.2 Drilling

Lakepine® E0 machines precisely so that exact diameter holes can be drilled provided the drill bit is sharp. For production line drilling it is advisable to use Tungsten-tipped drill bits. Drill speed should be as low as practicable when feeding in. To avoid polishing the hole wall, which could affect glue strength in the doweling operation, withdrawal speed should be as fast as possible.

5.3 Routing and edge moulding

One of the main advantages of Lakepine® E0 is its edge shaping capability. Edge banding and timber mouldings are eliminated with the contoured designs made possible with Lakepine® E0 products' quality edge.

The feed speed of boards into the cutter heads is important. At too high a speed, knife marks will be visible and the surface rough. At too low a speed, the cutters will not bite into the board but will simply abrade, causing edge burning and damaged cutting tips. The best finish requiring a minimum of sanding can be achieved from the following optional settings.

5.3.1 Recommended feed speeds for routing and moulding

Maximum feed speed (metre per minute) for routing and moulding:

Number of cutters	Cutter speed		
	3600rpm	5000rpm	7200rpm
1	5	7	10
2	10	14	20
3	15	21	30
4	20	28	40
6	30	42	60

Table 11

Tooling angles are generally greater than for natural wood, with hook angles between 10 and 25 degrees, and clearance angles 7 to 20 degrees, depending upon design. Face shear angles are usually 10 degrees.

5.4 Profile sanding

Sanding after moulding or routing produces a much smoother surface free of fuzz and eliminates the cost of fillers. Profile sanding can be by hand, however various polyurethane based abrasive wheels are available to fit to a low speed spindle or in line with a double end tenoner. These wheels can be shaped to the cutter profile using an abrasive paper glued to the desired edge profile. It should be remembered that the cutter and not the abrasive wheel determines the ultimate shape of the profile. Therefore the cutter must be well maintained because the abrasive wheel will not clean up areas of the profile which are poorly machined.

5.4.1 Sanding

Lakepine® E0 is supplied ready sanded to a high quality smooth finish which is suitable for most applications and finishes. Water-based or spray-on finishes or textured coatings must not be used (refer to section on finishing). For the economic application of high gloss paints or very thin foils, a further light sanding with 200 grit or even 240 grit belts may be advisable. High sanding belt speeds in excess of 1500 metres per minute cut the fibres most efficiently.

5.4.2 Dust extraction

Sanding operations on Lakepine® E0 product produces a very fine, light dust. For efficient sanding, operator comfort and safety, an effective, positive dust extraction system is essential.

5.5 Hand tools

Lakepine® E0 can also be simply worked with standard hand tools, which makes it ideal for intricate edge and face designs by craftsmen. For best results blades and cutters should be sharp at all times.

6 Fixing and Jointing

Fixing and jointing techniques with Lakepine® E0 are similar to methods used with most other wood products.

6.1 Balanced laminations

When surface coated or laminated, Lakepine® E0 products, as with all wood panel products must be treated both sides to reduce panel cup or bow which could otherwise occur at different humidity conditions.

6.2 Screwing

For best results and improved edge-screw holding over other types of wood panel products, the following should be observed.

6.2.1 Type of screw

The choice of screw is most important, especially when fixing into the edge of Lakepine® E0 panels. Recommended are particleboard screws.

6.3 Screw gauge

Maximum screw gauges when edge fixing into Lakepine® E0 are:

Board Thickness (mm)	9	12	16	18	25	30
Maximum Screw Gauge	5	6	7	8	9	10

Table 12

6.4 Pilot holes

Correct pilot holes are essential to avoid splitting of board edges.

Screw Gauge	3	4	5	6	7	8	9	10	12
Pilot Hole Size (mm)	1.0	2.0	2.4	2.6	2.7	3.0	3.3	3.5	4.1

Table 13

The pilot hole should be 3mm longer than the screw length. (Refer Figure 3).

It is important not to fix edge screws closer than 25mm from the corner of the board. Do not over tighten screws as further turning after screws are tight will reduce the holding power.

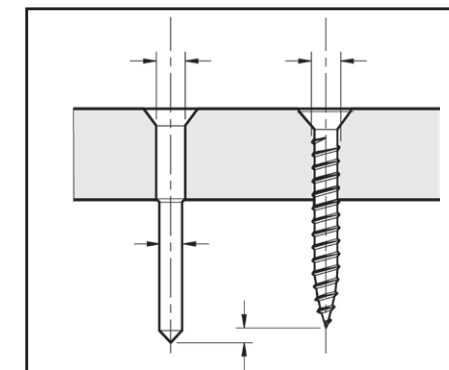

Figure 3

6.5 Nailing

Effective nailing can be achieved with Lakepine® E0 using Annular grooved nails and Helical spiral nails. Nailing is not recommended into edges of 9mm and 12mm Lakepine® E0 because of possible splitting. Nails should be no greater than 50mm x 2.2mm.

6.5.1 Airgun nails

Airgun nailing is suitable for volume production. Adjust air pressure to ensure that the nail head is driven just below the surface.

6.6 Stapling

When stapling into Lakepine® E0 panels it is important to regulate the air pressure to avoid excessive penetration of the staple. The top of the staple should be just below the surface to achieve the best holding power. In general, the staple length should be about twice the thickness of the board being fixed. (Refer Table 11).

6.6.1 Recommended staples

Thickness (mm)	Staple code No.	Length (mm)
12	L12/L13	20 -25
16	L15	32
18	L17	36

Table 14

When stapling into the edge, do not fix closer than 25mm from the corner of the Lakepine® E0 panel. Staples should be angled so that each leg is in a separate plane of the board. (Refer Figure 4).

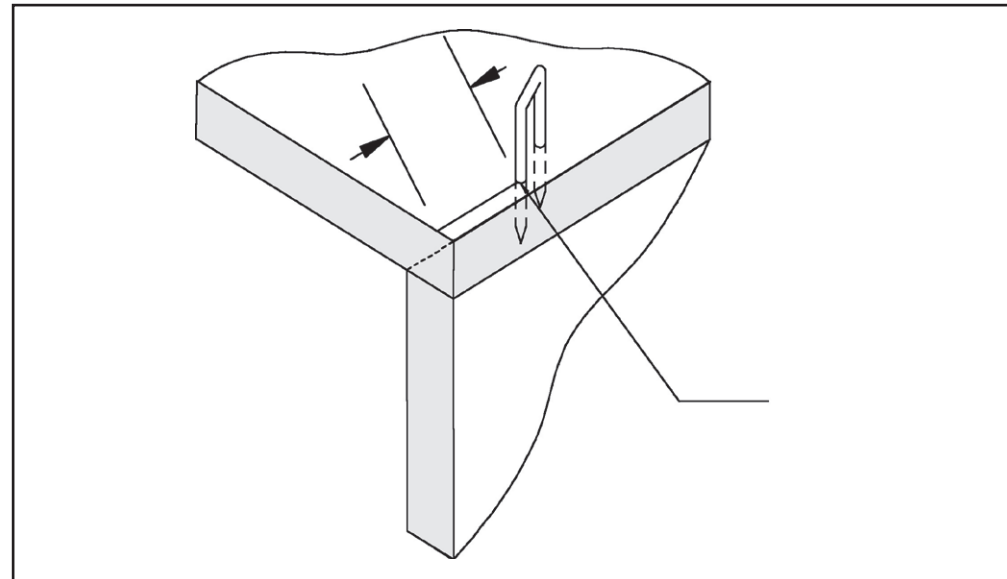

Figure 4

6.7 Doweling

Doweling is also recommended for jointing Lakepine® E0 panels. The hole diameter should be slightly larger than the dowel. (Refer Figures 5 & 5a) This will allow good adhesive coverage and avoid splitting of the edge. For best results dowels should be given total glue coverage and inserted with a thumb push. Glue formulation may have to be slightly thicker to avoid excessive penetration.

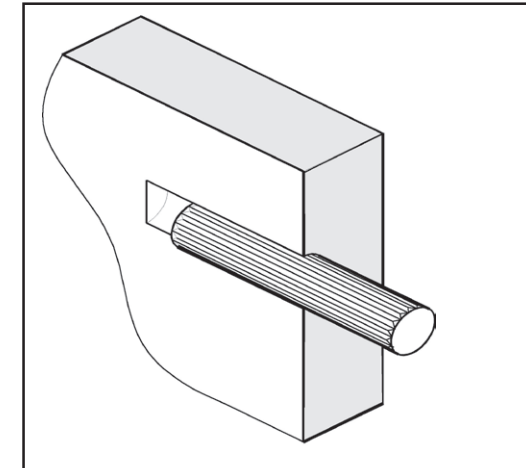

Figure 5

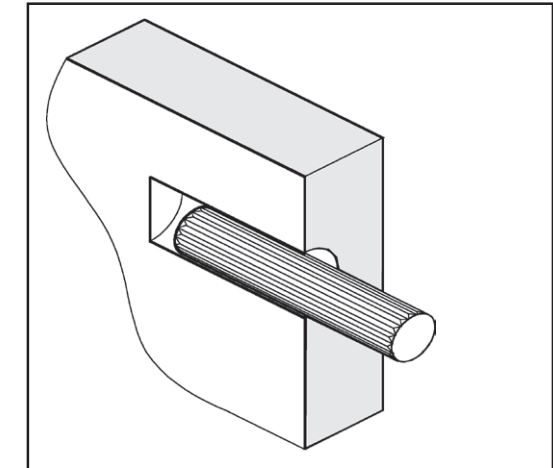

Figure 5a

6.8 Adhesives

Lakepine® E0 can be glued with most of the commercial brands of adhesives available on the market. The choice of adhesive will depend on the porous nature of the substrate being bonded, method involved for bonding and the atmospheric conditions. Sika Bonding Products are most common. Consult the adhesive manufacturer's instructions on the use of each adhesive.

6.9 Block laminating

Edge-cracking may occur when gluing several sheets of panels together face-to-face into thick blocks.

7 Finishing

The following recommendations are a general guide to finishing Lakepine® E0 products. For specialist coatings please contact the coating manufacturer for their advice.

7.1 Finishing limitations

All faces and surfaces of Lakepine® E0 products must be sealed or covered before service.

Lakepine® E0 products are not to be used for a flush plaster stopped wall or ceiling lining that is to be subsequently wall papered or painted. (Exceptions to this apply to proprietary glued drywall partition systems.)

The application of water based fillers or spray applied textured coatings is not recommended.

Water based paints and undercoats can cause raising of board fibre which will require de-nibbing before subsequent coatings.

7.2 Preparation

7.2.1 Edge preparation

The edge finish achieved on Lakepine® E0 products can be comparable with the quality of the face provided care is taken in sanding and sealing.

- o Sand edges with a 120 to 150 grit paper followed by 240 to 320 grit paper.
- o Remove all dust.
- o Be careful if using air guns that the compressor filters are clean i.e. no oil or water, this will avoid contaminating the surface before painting.
- o In polishing shops, edges should be sealed on the same day as sanding since moisture in the air may cause the fibres to stand up and give an unsatisfactory factory finish.
- o A very light sand after sealing will also improve the edge finish.

7.2.2 Surface preparation

- o Lightly sand all surfaces to be painted with a 240 to 320 grit paper.
- o Remove all dust.

7.2.3 Stopping

All nail/staple/screw holes shall be filled with solvent based proprietary fillers. Avoid the use of water based filler especially plaster based fillers.

Fillers must be used in accordance with the filler manufacturers' instructions. Sand level and finish off with 240 – 320 grit paper.

When a high quality paint or lacquer finish is required and joints need to be sealed, a two pot epoxy filler is suggested. This will seal joints and reduce the chance of paint cracks due to humidity changes.

The use of thermosetting glues in joints is also essential when finishes such as high quality paint or lacquer is required. It is also preferable on high quality finishes not to screw, nail or staple through the face of the cabinet or desk top etc. Instead some form of hidden joint system should be used. This will avoid sink back of fillers or show through of joints after they have been coated.

Note:

The sanding operation is extremely important to achieving the desired final finish. All raised fibres should be removed by sanding the surfaces prior to each subsequent coat being applied. Ensure all surfaces are free of dust prior to the application of the next coat.

7.3 Brush paint application

7.3.1 Priming

The first application of primer undercoat is critical to the final finish. This is the application which effectively seals the Lakepine® E0 MDF component.

To obtain the best results:

- o The first coat should not be thinned.
- o Wait the specified drying time before lightly sanding.
- o Sand with 280 to 320 grit paper.

7.3.2 Finishing

- o Apply the second coat in accordance with the paint manufacturer's instructions.
- o Wait the specified time for drying.
- o Lightly scuff sand the surface with 320 grit sand paper.
- o Ensure all sanding dust is removed.
- o Repeat the above recommendations for the third coat application.
- o If additional finish build-up is required, repeat the preceding steps.

7.4 Spray coating application

Users of spray equipment should seek advice from the particular manufacturer or supplier of the equipment being used for instructions.

7.4.1 Sealing

The first coat of sealer is critical to a successful final finish.

- o The first coat should only be thinned enough to allow the paint to atomise for spraying. This will assist drying speed and enhance the final finish. Note: One coat is usually sufficient.
- o When a high quality finish is required, the first sealer coat should be a medium coat followed by a full coat.
- o A 280 to 320 grit sandpaper between coats will enhance the finish quality.

7.4.2 Finishing

- o After drying, lightly scuff sand the surface with 320 grit sand paper.
- o Remove all dust before applying further coats. Note: Coatings should be applied according to coating manufacturer's instructions.
- o Lightly scuff sand the surface between each coat with a 320 grit sand paper and remove all dust.

8 Health and Safety

8.1 Health and safety precautions

Health and safety precautions must be taken when working with wood products. The following information is intended as a guide to help keep you safe.

8.2 Wood dust

- o Exposure to wood dust and/or to formaldehyde may cause irritation to the eyes, respiratory system, skin and may cause sensitisation resulting in asthma, and by skin contact resulting in dermatitis.
- o Wood dust is classified as a known carcinogen. Repeated inhalation of wood dust over many years may cause nasal cancer.
- o Work areas must be well ventilated and kept clean. Sawing, sanding and machining equipment must be fitted with efficient working dust extractors capable of extracting fine dust created by working with wood to ensure dust levels are kept within standards set by WorkSafe Australia and WorkSafe New Zealand, or the specific country of use. Hand power tools should be fitted with dust collection bags.
- o The use of a dust mask should be considered a last line of defence (a low-level control) and should not be considered as the only form of safety equipment to be used. All dust masks must conform with AS/NZS 1716 and be kept clean for regular use in accordance with AS/NZS 1715: 2009. Eye protection must also be worn which complies with AS/NZS 1337.
- o Offcuts, shavings and dust must be disposed of in a manner which avoids the generation of dust and in accordance with the requirements of local waste authorities. Do not use air lines to blow areas/machines clean. It is recommended you use a vacuum fitted with a HEPA filter. Dispose of dust regularly to avoid build up and risk of fire or explosion.
- o In end use applications all product surfaces exposed to occupied space must be sealed.
- o For further information and safety data information, please phone Laminex® New Zealand Customer Services Department, 0800 303 606.

8.3 Formaldehyde

- o Formaldehyde is also classified as a known carcinogen.
- o The formaldehyde content of Lakepine® E0 MDF products comply with the limits specified by the World Health Organisation for low formaldehyde emitting products and meets the requirements for E0 product as detailed in AS/NZS 1859.2:2017 – Reconstituted wood-based panels – Specifications.
- o When tested to AS/NZS 4266.1:2017, the extractable formaldehyde content is <0.5 milligrams per litre for E0.
- o Storage areas containing large quantities of board must be adequately ventilated. Airborne formaldehyde is detectable by smell at about 0.3 - 0.4 parts per million (ppm). At this level it may cause eye irritation for some people. At 0.5 ppm mild throat effects are noted. At 1.0 ppm and over, watering of the eyes begins. At 10 ppm the effects are intolerable. To avoid health issues, adequate ventilation is key.
- o Once Lakepine® E0 MDF products are installed, emission levels can be controlled by room ventilation together with covering or coating the surface and edges.

8.4 Warranty

Laminex® New Zealand will not be liable to any persons if the conditions as to storage, handling and installation and maintenance of Lakepine® E0 as outlined within the Lakepine® E0 Technical Manual are not complied with. It is the obligation of the installer of the Lakepine® E0 to convey this information to the relevant owner/occupant.

If you have any questions, or in the unlikely event of a problem with Lakepine® E0, please contact Laminex® New Zealand Customer Services. For more information visit laminex.co.nz or call 0800 303 606.

9 Disclaimer

Laminex® New Zealand will not be liable to any person if the instructions as to storage, use and installation of Lakepine® E0 as outlined in this brochure are not complied with.

Any proprietary products referred to in this brochure must be used in accordance with the relevant manufacturer's instructions. Laminex® New Zealand accepts no liability for these proprietary products.

All Acts, Codes and Standards referred to in this brochure are the current editions at the date of brochure publication.

9.1 Technical support

As not all product use options can be described in this brochure, additional end use and specifying information is available. The information contained in this brochure must not be reproduced or published in whole or in part without the prior consent of Laminex® New Zealand. Laminex® New Zealand reserves the right to revise without notice any information contained in this brochure.

VISIT US

laminex.co.nz

CALL US

0800 303 606

J004801 - 12/19

©Copyright reserved, April 2019, Laminex® New Zealand. Lakepine® E0 is marketed and distributed by Laminex® New Zealand, a division of Fletcher Building products Ltd. Laminex® New Zealand, Lakepine® E0 MDF, Lakepine® E0 Light logo, Lakepine® E0 MR logo are trademarks of Fletcher Building Holdings and used under license by Laminex® New Zealand.

Laminex[™]
NEW ZEALAND